

HALF CUT WALL PACKS 45W-70W

A terrific source of light for any outdoor application. Half cut wall packs offer a direct replacement for any exterior areas where illumination is required. Our wall packs provide a direct replacement to traditional wall packs while blending outstanding technical innovation with quality design.



FEATURES

- Outstanding optical design providing an efficient light source.
- Anti-glare design enables a high safety rating.
- Built-in thermal conductivity aluminum heat sink ensures excellent heat dissipation extending lifespan.
- High lumen output is ideal for illuminating large exterior spaces.
- Wide input voltage, AC100-277/AC200-480V.
- Available in 45W and 70W.
- Custom housing colour options available.
- Suitable for wet locations.
- Saves up to 60% energy consumption compared to traditional lighting.

GWL NOVUS

Product Parameters

MODEL	WATTS	INPUT VOLTAGE	LUMINOUS FLUX	CCT	CRI	BEAM ANGLE	WARRANTY	WORKING TEMP	MATERIAL
GWL-HWP-45-PF-XX-C	45W	AC100-277V	≥5408lm	3000K 4000K	≥80	60-90°	5 years	-30° -50° C	Aluminium & PC
GWL-HWP-70-PF-XX-C	70W	or AC200-480V	≥8474lm	5000K					

Product Dimensions

GWL-HWP-45-PF-XX-C

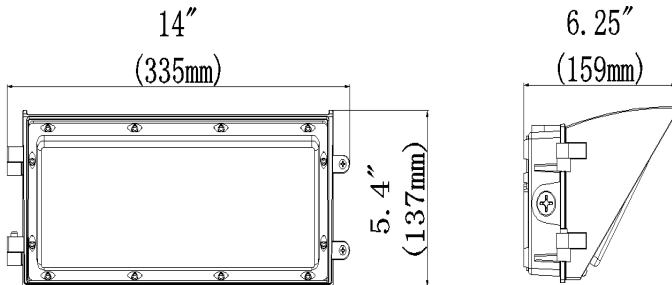

FDK-HWP-70-PF-XX-C

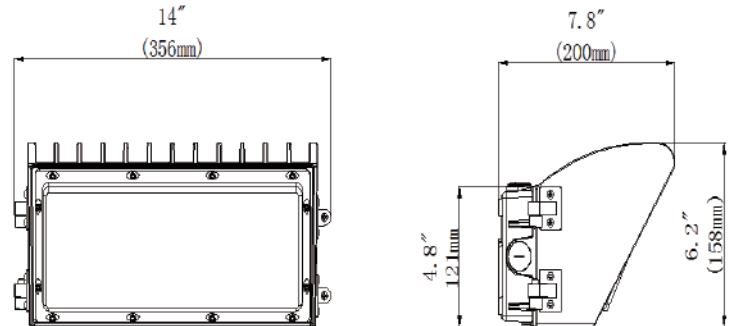

Product Order Code

GWL	PF	XX	PF	XX	C
—	—	—	—	—	—
GWL	PRODUCT SERIES	WATTAGE	INPUT VOLTAGE	CCT	CONTROL
	HWP - Half Cut Wall Packs	45 - 45 watt 70 - 70 watt	27 - AC100-277V 48 - AC200-480V	30K - 3000K 40K - 4000K 50K - 5000K	P27-277V Photocell P48-480V Photocell

