

## SLIM SHOEBOX FLOOD 60W-300W

A terrific source of light for any exterior application where illumination is required. Widely used for outdoor basketball courts, tennis courts, football fields and gymnasiums. With a stylish and modern design, our Slim Shoebox has the ability to deliver high quality illumination to meet all of your outdoor lighting needs, while withstanding the most adverse climate conditions.



### FEATURES

- High lumen output which is ideal for illuminating large, open spaces.
- Built-in thermal conductivity aluminum heat sink ensures excellent heat dissipation extending lifespan.
- Direct wall or pole mounting options.
- Wide input voltage, AC100-277/AC200-480V
- Available in 60W, 100W, 150W, 200W and 300W.
- Dimmable, photocell and occupancy sensors are available.
- Custom housing colour options available.
- Suitable for wet locations.
- Saves up to 60% energy consumption compared to traditional lighting.

# GWL NOVUS

## Product Parameters

MODEL	WATTS	IMPVT VOLTAGE	LUMINOUS FULX	CCT	CRI	BEAM ANGLE	WARRANTY	WORKING TEMP	MATERIAL
GWL-SSB-XX-06-XX-PF-XX-C	60W	AC100-277V or AC200-480V	≥8760	3000K 4000K 5000K	≥80	120°	5 years	-40° -50° C	Aluminium
GWL-SSB-XX-10-XX-PF-XX-C	100W		≥13600						
GWL-SSB-XX-15-XX-PF-XX-C	150W		≥21000						
GWL-SSB-XX-20-XX-PF-XX-C	200W		≥27000						
GWL-SSB-XX-30-XX-PF-XX-C	300W		≥39000						

## Product Dimensions

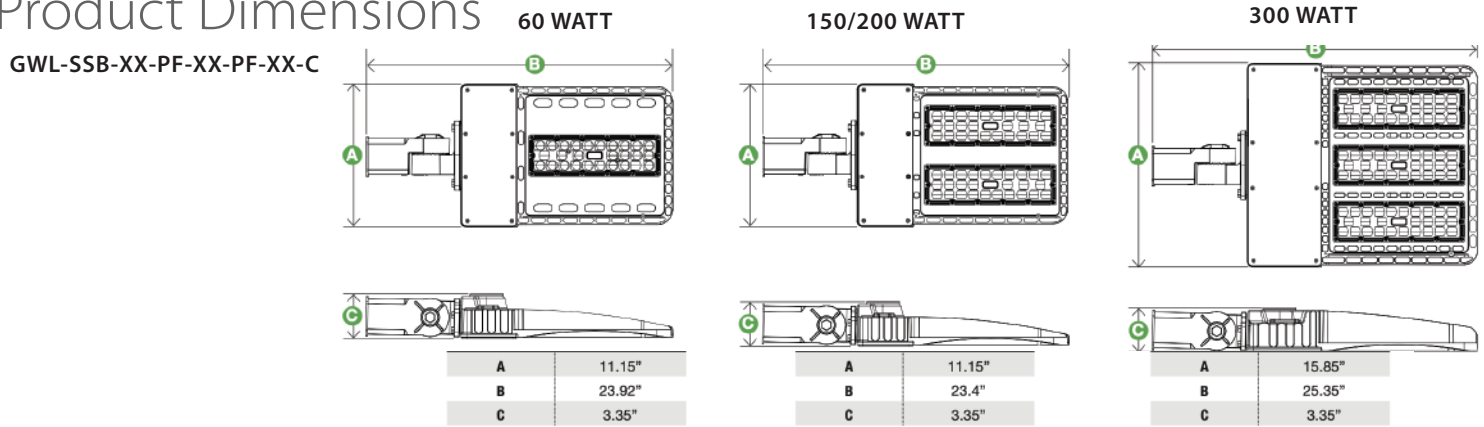

SLIP FITTER  
(2"-2-3/8")



FLAT ARM MOUNT



TRUNNION MOUNT



ROUND POLE  
ADAPTER

## Product Order Code

<b>GWL</b>	<b>PF</b>	<b>XX</b>	<b>PF</b>	<b>XX</b>	<b>PF</b>	<b>XX</b>	<b>C</b>
GWL	PRODUCT SERIES SSB - Slim Shoebox	INPUT VOLTAGE 27-AC100-277V 48-AC200-480V	WATTAGE 06 - 60 watt 10 - 100 watt 15 - 150 watt 20 - 200 watt 30 - 300 watt	CCT 30K - 3000K 40K - 4000K 50K - 5000K	DISTRIBUTION TYPE T2 T3 T4 T5	MOUNTING TYPE A - Arm S - Slip Fitter T - Trunnion	CONTROL P27-277V Photocell P48-480V Photocell M - Motion Sensor

